

## Installation Guide

### RAVB Replacement Kit 013X3180 & 013X3182

The RAVB replacement kit allows for the replacement of the RAVB thermostatic operator. The RAVB thermostatic operator is distinguishable by the attachment base of the operator. The operator's base has a 3 "prong" style base for attachment to the double solder straight valve.

The RAVB adapter kit contains the assembly required to replace the RAVB thermostatic operator with the current RA2000 style of thermostatic operator. Within the adapter kit contains 3 items:

1. RAVB to RA2000 base adapter
2. Valve stem extension
3. Valve mounted dial style of thermostatic operator

	<b>Replacement Kit</b>	<b>Code No.</b>
	Replacement kit, with valve mounted dial and sensor	<b>013X3180</b>
	Replacement kit, with valve mounted dial with remote (6ft) sensor	<b>013X3182</b>

### Installation

1. Carefully remove the non-functioning RAVB thermostatic operator. If the RAVB operator has a remote sensor, locate the sensor by following the capillary tube and remove the remote sensor from the mounting.

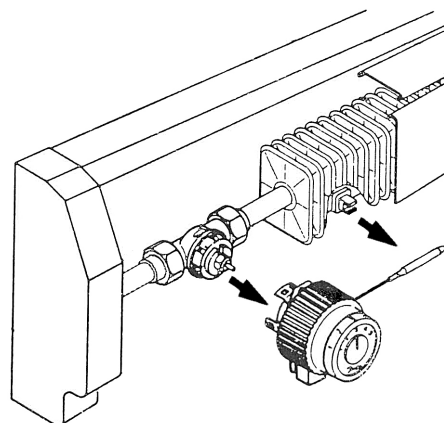

2. Place the adapter with the slotted screw pointing upwards over the 'sprockets' on the valve and turn the adapter to grip the 'sprockets'. With a screw driver tighten the adapter to secure it to the RAVB valve.

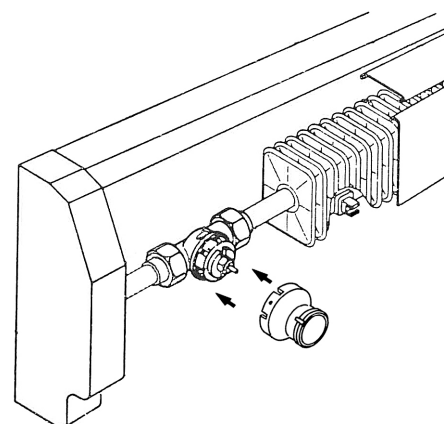

3. Place the stem extension over the packing gland pin.
- If the packing gland needs to be replaced a replacement packing gland can be ordered for the RAVB, code no. 013U0070.

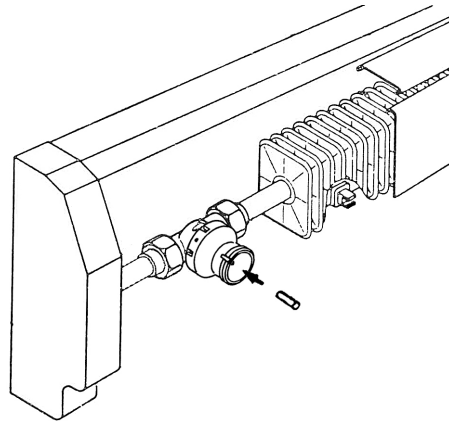

4. Mount the thermostatic operator to the valve. Refer to the installation instructions of the thermostatic operator to properly mount it to the valve.

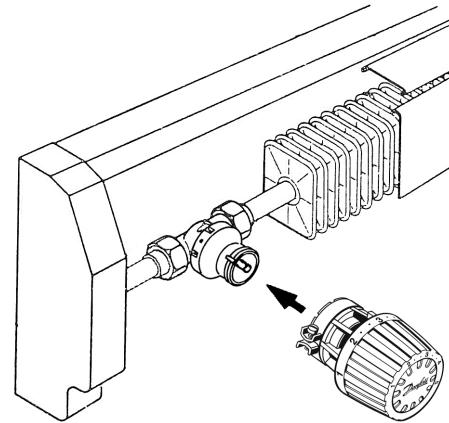

5. If the replacement thermostatic operator has a remote sensor, mount it in an appropriate location as reflected in the operator instructions.

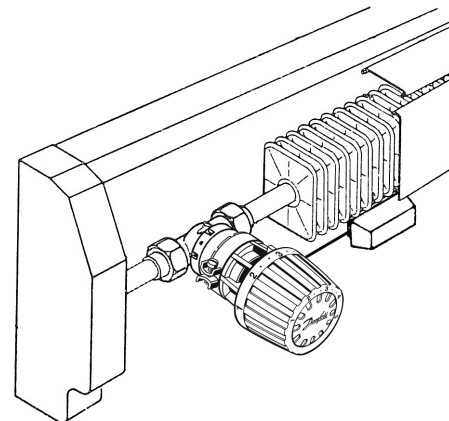

## Operation Instructions

For complete details of the installation of the operator, refer to the enclosed style of thermostatic operator.

**USA Office:**  
 Danfoss LLC  
 Baltimore, MD, 21220  
 Tel: 800.375.4822 Fax: 443.512.0270

**Canadian Office:**  
 Danfoss LLC  
 Mississauga, ON, L5N 2W3  
 Tel: 800.375.4822 Fax: 443.512.0270

Danfoss can accept no responsibility for possible errors in catalogues, brochures and other printed material. Danfoss reserves the right to alter its products without notice. This also applies to products already on order provided that such alterations can be made without subsequential changes being necessary in specifications already agreed. All trademarks in this material are property of the respective companies. Danfoss and the Danfoss logotype are trademarks of Danfoss A/S. All rights reserved.